

# Christensen CS3001 Truck Mounted Core Drill



*Atlas Copco*

# CS3001 TRUCK MOUNTED DRILL PERFORMANCE SPECIFICATIONS

## DEPTH CAPACITY CORING\*

B WIRELINE		2,360 M (7,740 FT)
N WIRELINE		1,830 M (6,000 FT)
N WIRELINE	UPSET ENDS	2,120 M (6,950 FT)
H WIRELINE		1,200 M (3,930 FT)
P WIRELINE		830 M (2,720 FT)

\* for vertical, straight and water filled hole

## MAST AND FEED SYSTEM

FEED TRAVEL: 3.35 M (11 FT)  
 FEED SPEEDS: FAST AND SLOW WITH VARIABLE CONTROL  
 PULL BACK: 155 KN (35,000 LBF)  
 THRUST: 62.2 KN (14,000 LBF)  
 ROD PULL LENGTH: 6.1 M (20 FT)  
 DRILLING ANGLE: 45 TO 90 DEGREES  
 MAST DUMP: 2 M (80 IN)

## POWER UNIT

MFG.: CUMMINS QSC PU 8.3 LITER 6 CYLINDER  
 POWER: 212 KW (285 HP) @ 2,000 RPM  
 TYPE: DIESEL TURBO CHARGED/CHARGE AIR COOLED  
 COOLING: WATER

## HYDRAULIC PUMPS

PRIMARY PUMP: ROTATION, HOIST, W/L HOIST, FAST FEED  
 AUXILIARY PUMP: SLOW FEED, CHUCK, FOOT CLAMP, MUD MIXER  
 SECONDARY PUMP: MUD PUMP

## CHUCK ASSEMBLY

MAXIMUM INSIDE DIAMETER: 117 MM (4 5/8 IN)  
 HOLDING CAPACITY: 178 KN (40,000 LBF)  
 OPERATION: SPRING APPLIED, HYDRAULICALLY OPENED

## DRILLHEAD

MAXIMUM RPM: 1,300  
 MAXIMUM TORQUE: 4,810 NM (3,500 FT LBF)  
 TRANSMISSION: FOUR SPEED, MANUAL SHIFT  
 MOUNTING: HYDRAULIC POWERED SWING AWAY  
 LUBRICATION: PRESSURE SYSTEM

## MAIN HOIST

SINGLE LINE CAPACITY: 133 KN (30,000 LBF)  
 LINE SPEED: 42 – 70 M/MIN (138 - 230 FPM)  
 CABLE DIAMETER: 19 MM (3/4 IN)

## WIRE LINE HOIST CAPACITY

1,460 M (4,780 FT) OF 6.35 M (1/4 IN) CABLE  
 2,600 M (8,530 FT) OF 4.76 MM (3/16 IN) CABLE  
 LINE SPEED: BARE 1.1 M/S (220 FPM), FULL 4.3 M/S (220 FPM)  
 LINE PULL: BARE 15 KN (3,370 LBF), FULL 4.0 KN (900 LBF)

## STANDARD EQUIPMENT

FOUR HYDRAULIC JACKS 610 MM (24 IN) STROKE  
 HYDRAULIC P-SIZE HOLDING CLAMP  
 CONTROL PANEL HYDRAULIC SLIDE  
 HIGH ALTITUDE KIT  
 HYDRAULIC MUD MIXER  
 FUEL TANK 950 L (250 GAL)  
 MUD PUMP: HYDRAULIC DRIVEN FMC W1122BCD  
 MAX FLOW: 140 LPM (37 GPM)  
 MAX PRESSURE: 7.0 MPA (1,000 PSI)

## OPTIONS:

ROD SPINNER FOR ROD BREAKOUT

## WEIGHT

RIG WEIGHT: 11,300 KG (24,900 LBS) – will vary with options  
 RECOMMENDED TRUCK GVW: 20,000 KG (44,000 LBS)

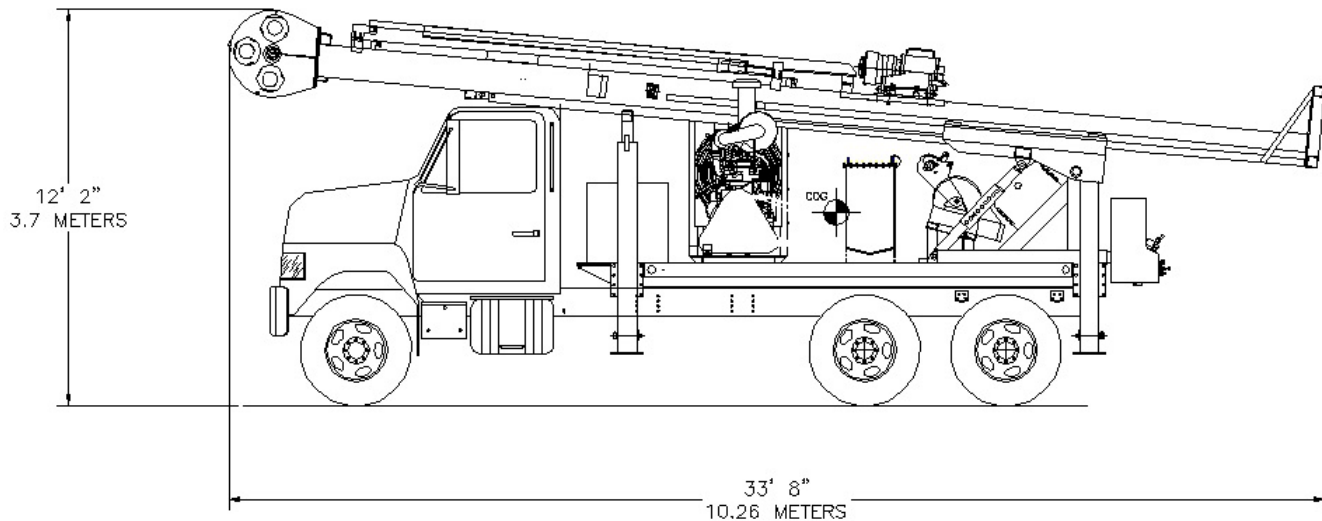

ALL WEIGHTS AND DIMENSIONS ARE APPROXIMATE AND SUBJECT TO CHANGE



Atlas Copco Exploration Products  
 640 McKeown Avenue,  
 North Bay, Ontario  
 Canada  
 Tel (705) 472-3320, Fax (705) 472-6843  
[www.atlascopcoexploration.com](http://www.atlascopcoexploration.com)