

Christensen CS4002 Truck Mounted Core Drill



CS4002 TRUCK MOUNTED DRILL PERFORMANCE SPECIFICATIONS

DEPTH CAPACITY CORING*

N WIRELINE		2,450 M (8,030 FT)
N WIRELINE	UPSET ENDS	2,850 M (9,350 FT)
H WIRELINE		1,600 M (5,250 FT)
P WIRELINE		1,050 M (3,440 FT)

* for vertical, straight and water filled hole

MAST AND FEED SYSTEM

FEED TRAVEL: 3.35 M (11 FT)
FEED SPEEDS: FAST AND SLOW WITH VARIABLE CONTROL
PULL BACK: 200 KN (45,000 LBF)
THRUST: 89 KN (20,000 LBF)
ROD PULL LENGTH: 6.1 M (20 FT) OR 9.1 M (30 FT)
DRILLING ANGLE: 45 TO 90 DEGREES
MAST DUMP: 2 M (80 IN)

POWER UNIT

MFG.: CUMMINS QSC PU 8.3 LITER 6 CYLINDER
POWER: 212 KW (285 HP) @ 2,100 RPM
TYPE: DIESEL TURBO CHARGED/CHARGE AIR COOLED
COOLING: WATER

HYDRAULIC PUMPS

PRIMARY PUMP: ROTATION, HOIST, W/L HOIST, FAST FEED
AUXILIARY PUMP: SLOW FEED, CHUCK, FOOT CLAMP, MUD MIXER
SECONDARY PUMP: MUD PUMP

CHUCK ASSEMBLY

MAXIMUM INSIDE DIAMETER: 117 MM (4 5/8 IN)
HOLDING CAPACITY: 178 KN (40,000 LBF)
OPERATION: SPRING APPLIED, HYDRAULICALLY OPENED

DRILLHEAD

MAXIMUM RPM: 1,300
MAXIMUM TORQUE: 6,230 NM (4,596 FT LBF)
TRANSMISSION: FOUR SPEED, MANUAL SHIFT
MOUNTING: HYDRAULIC POWERED SLIDE AWAY
LUBRICATION: PRESSURE SYSTEM

MAIN HOIST

SINGLE LINE CAPACITY: 178 KN (40,000 LBF)
LINE SPEED: 36 – 71 M/MIN (117 - 232 FPM)
CABLE DIAMETER: 22 MM (7/8 IN)

WIRE LINE HOIST CAPACITY

2,600 M (8,530 FT) OF 6.35 M (1/4 IN) CABLE
4,600 M (15,090 FT) OF 4.76 MM (3/16 IN) CABLE
LINE SPEED: BARE 1.38 M/S (272 FPM) FULL 5.1 M/S (1004 FPM)
LINE PULL: BARE 28.5 KN (6,380 LBF) FULL 5.1 KN (1,151 LBF)

STANDARD EQUIPMENT

FOUR HYDRAULIC JACKS 610 MM (24 IN) STROKE
HYDRAULIC P-SIZE HOLDING CLAMP
CONTROL PANEL HYDRAULIC SLIDE
HIGH ALTITUDE KIT
HYDRAULIC MUD MIXER
FUEL TANK 950 L (250 GAL)
MUD PUMP: HYDRAULIC DRIVEN FMC W1122BCD
MAX FLOW: 140 LPM (37 GPM)
MAX PRESSURE: 7.0 MPA (1,000 PSI)

OPTIONS:

FOLDING MAST EXTENSION FOR 9.1 M (30 FT) PULL
ROD RACK AND HELPER'S PLATFORM FOR 9.1 M PULL MAST
ROD SPINNER FOR ROD BREAKOUT

WEIGHT

RIG WEIGHT: 13,380 KG (29,500 LBS) – will vary with options
RECOMMENDED TRUCK GVW: 20,000 KG (44,000 LBS)

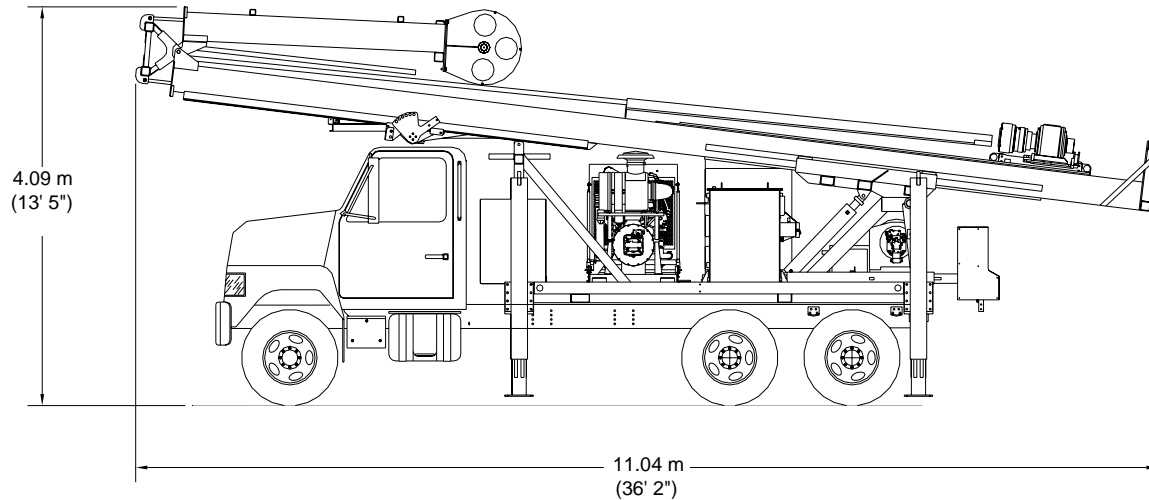

ALL WEIGHTS AND DIMENSIONS ARE APPROXIMATE AND SUBJECT TO CHANGE

Atlas Copco

Atlas Copco Exploration Products
640 McKeown Avenue,
North Bay, Ontario
Canada
Tel (705) 472-3320, Fax (705) 472-6843
www.atlascopcoexploration.com